

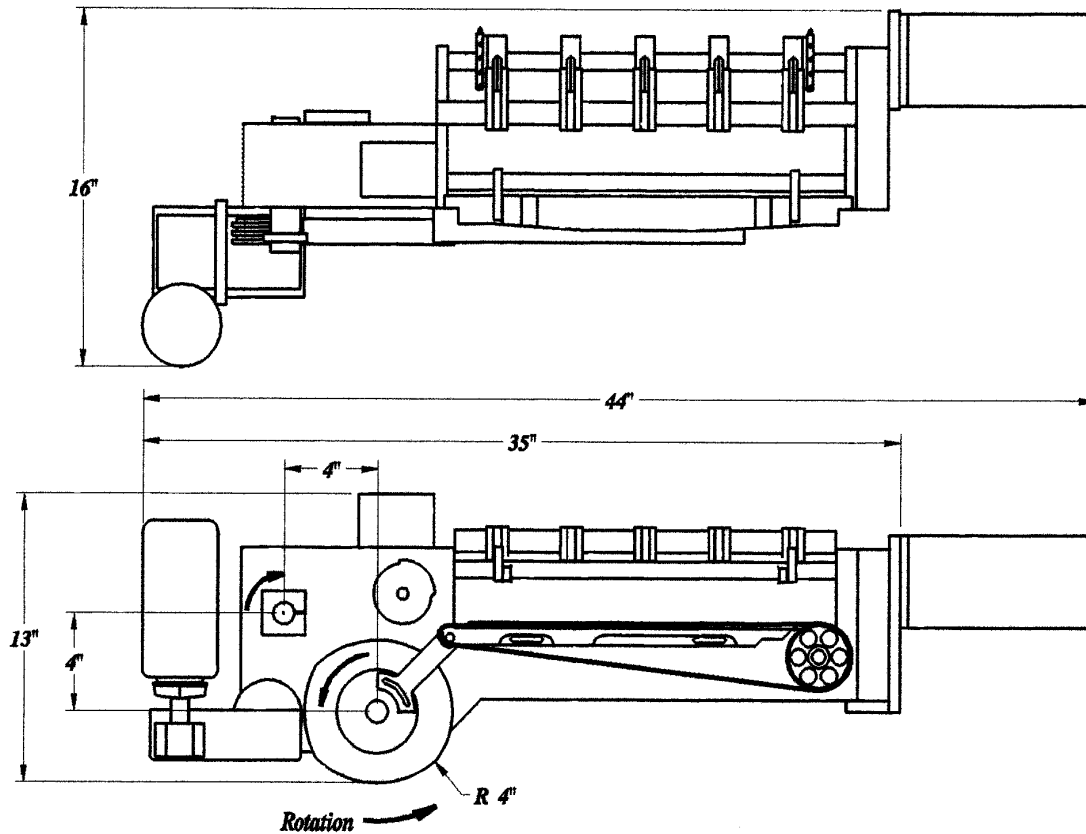

KR 211E LABELING HEAD

Kirk-Rudy, Inc. • 125 Lorraine Parkway • Woodstock, GA 30188
Phone: (770) 427-4203 • Fax: (770) 427-4036



Features:

- ◆ Stepper motor for precise list indexing – ideal for pressure sensitive or odd size labels (example: 1 1/3" wide labels)
- ◆ Dial control for format changes – no gear change necessary
- ◆ Solid state circuitry in a self-contained, portable cabinet
- ◆ Mechanical clutch disengages label feeding during media misfeed cycles
- ◆ Applies individual address labels to media with label formats from 1-up to 5-up label formats
- ◆ Processes margin punch forms with widths of 4" to 16"

Options:

- ◆ "No Tools" label belt stroke adjustment kit
- ◆ Differential for "on-the-fly" adjustment of label position
- ◆ 90 degree label rotation kit
- ◆ Various label sizes available on request

Specifications:

- ◆ Power Requirements:
Mechanical: 1/2 horsepower
Input drive: 1" diameter shaft

Electrical: Control Box
120 VAC, 60 Hz, 3.0 Amp
- ◆ Vacuum Requirements:
26.5" HG @ 8.0 CFM Open Flow
- ◆ Label Requirements:
Length: Minimum 2.6"
Maximum 4.5"

Width: Standard 1.0"
Barcode 1.5" & 2.0"

**Specifications subject to change without notification

**Guards have been removed for clarity; do not operate machine without guards in place